

UNO ACCESSORIES

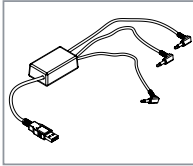

ASL 802/4 ECU Interface Cable

The ASL 802-4 ECU Interface Cable – 4 Mono Plugs converts commands from the auxiliary port into a mono input. It can be used for functions such as tilting or reclining the power wheelchair, accessing a computer, a communication device, or anything that requires a mono plug. The forward mono jack plug is the activation for selection while in the auxiliary mode.



ASL 557-3 ATOM Bluetooth Wireless Switch Receiver

The ASL 557-3 ATOM Bluetooth Wireless Switch Receiver is intended to be used for Bluetooth wireless access to communication devices, TECLA Shield, TECLA E, or switch interfaces on a computer. The USB side plugs into a communication device directly, or into a computer. Each plug corresponds to the pad on the head array (forward, right, or left). You can connect the plugs to the scan and select ports of a communication device, switch interface or TECLA ports. If using with the TECLA products, you need a rechargeable battery.

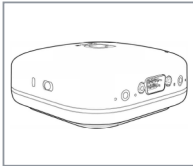

ASL 545E Tecla - Bluetooth Interface

Tecla is a cloud connected assistive device that provides users with control of their smart device and environment. Using Bluetooth, Tecla connects directly to ATOM technology whenever the ATOM is in wireless mode. ATOM technology speaks directly to the Tecla which is able to connect up to 8 devices. You can use Tecla with iPhone, iPad, iPad Touch, Mac computers with switch control, Apple TV's with switch control, Android devices with switch access, Samsung devices with universal switch and Windows computers with scanning software.

SECURITY MEASURES

A reset switch should always be plugged into a reset port programmed to stop the chair and be available in case of emergency to stop movement of the wheelchair. The ASL 102 UNO Bluetooth Single Switch Scanner is susceptible to moisture. If moisture contacts a sensor, unwanted movement may occur. Do not operate the ASL 102 UNO Bluetooth Single Switch Scanner in rain or snow.

Installation of the ASL 102 UNO Bluetooth Single Switch Scanner and the programming of the wheelchair electronics should only be conducted by a specialist with an in depth technical knowledge of the ASL 102 UNO Bluetooth Single Switch Scanner and the wheelchair electronics. All testing and verification of the completed wheelchair equipment with the ASL 102 UNO Bluetooth Single Switch Scanner to ISO/RESNA or applicable standards for the completed wheelchair, including RFI compatibility testing, is the sole responsibility of the wheelchair manufacturer.

WARRANTY

The ASL 102 UNO Bluetooth Single Switch Scanner is warranted to be free from manufacturing defects for two years from date of purchase.

This warranty shall not cover equipment modified or repaired by unauthorized personnel. ASL cannot be held responsible for damage caused by incorrect installation or incorrect use of the product. Misuse, mishandling, or storage is not covered by this warranty. The foregoing express warranty is exclusive and in lieu of any other warranties of any kind, whether express or implied, including the implied warranties of merchantability or fitness for a particular purpose, and is the sole and exclusive remedy for any defective product. The health care professional is responsible for understanding the intended use of the ASL equipment and the specification and safe programming parameters of the chair it is going on. The wheelchair manufacturer is responsible for testing and verification of the completed wheelchair equipped with the ASL 102 UNO Bluetooth Single Switch Scanner to ISO, RESNA or other applicable standards including RFI compatibility. RFI interference can impact the proper functioning of the wheelchair. Route and secure all cables in such a way in order to prevent damage by crushing, cutting or snagging. Incorrect installation, configuration, or programming could result in unsafe set up of the wheelchair for the user. ASL accepts no liability for losses of any kind which result for such conditions.



ASL 102 UNO BLUETOOTH SINGLE SWITCH SCANNER

102 UNO FULL ASSEMBLY

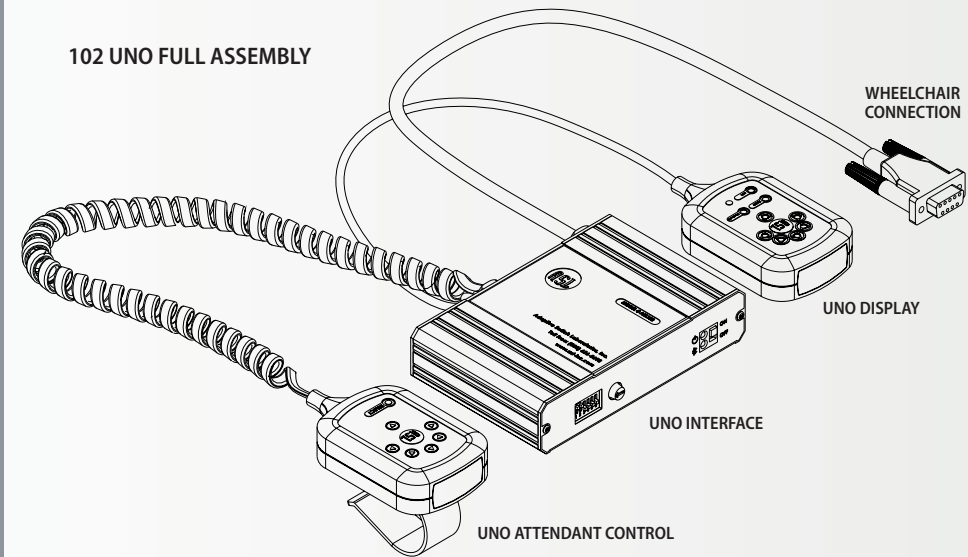

CONNECTION REQUIREMENTS:

- LiNX Input Module
- MK6i Digital Interface
- Omni or Omni 2
- Enhanced Display or SCIM



SCAN FOR PROGRAMMING INFORMATION



UNO SINGLE SWITCH SCANNER EXPLANATION OF PARTS

DISPLAY OVERVIEW

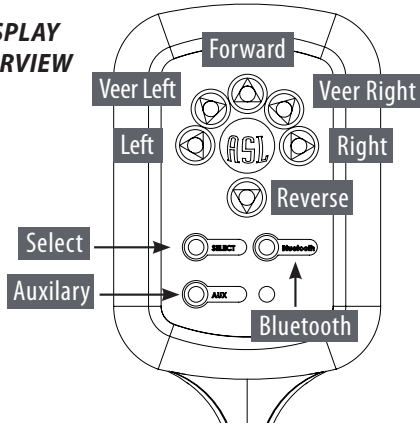

ATTENDANT OVERVIEW

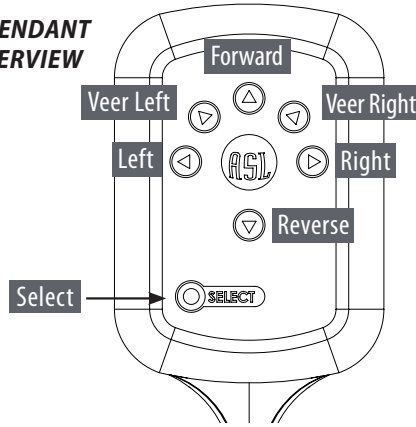

INTERFACE OVERVIEW

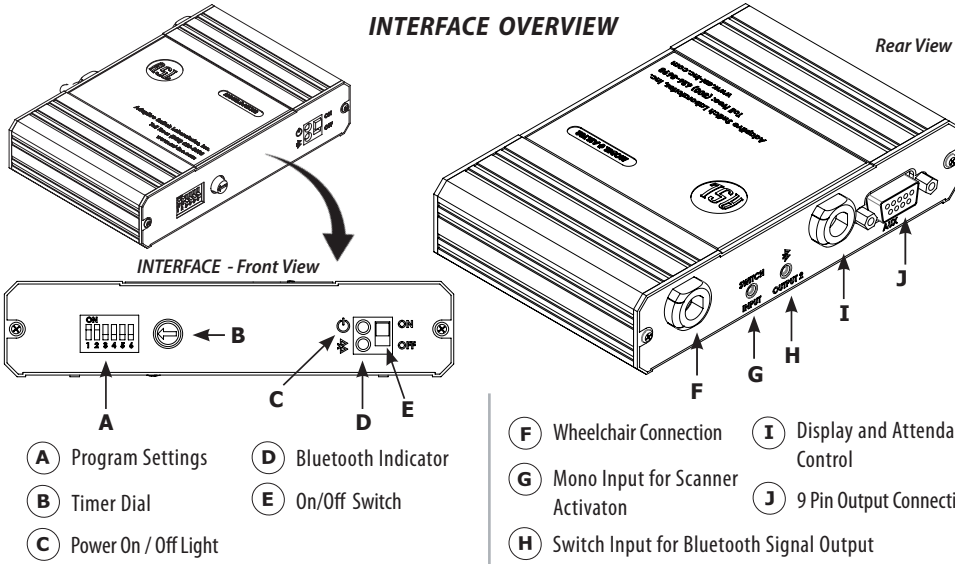

DIP SWITCH SETTINGS

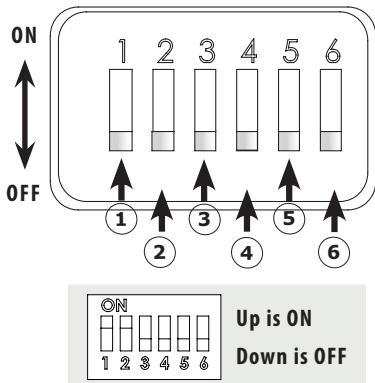

Switch 1 Veer On/Off – If dip switch 1 is set in the OFF position the scanner will not cycle the veer selections. The scan pattern will be Forward, Right, Left, Reverse, Select, then to the BT and AUX if they are set to the ON position.

1a) Veer On – The switch set in the ON position will cycle through Veering in the *Scan Pattern*. The scan pattern is Forward, Right, Left, Reverse, Select. If the switch is activated in forward the veer right and veer left will scan next, If forward is not activated the scanner will scan right and left next.

Switch 2 Switch Delay – Sets a 1 second delay in moving back to forward. If a patient has a hard time with releasing a switch too soon, this will cause a delay before the scanner moves back to forward.

DIP SWITCH SETTINGS CONTINUED

Switch 3 Enable Bluetooth – when in the up position the scanner BT light will be scanned to, once it is selected the same switch will connect to an ASL Accessory ASL 545 TECLA E or the ASL 557-3. The scanner will stay in the BT mode until the switch is held for 5 seconds, once it is held for 5 seconds the scanner will start scanning the drive selections again.

Switch 4 Enable AUX –When in the up position the scanner will scan to the AUX mode, when AUX is selected it will allow a single switch to function from the 9 pin connector (See *F Interface Overview*) on the bottom of the scanner interface. Once connected the same switch will activate what ever the mono jack is plugged into. This can be used to connect a AAC device, or anything that uses a single switch. The scanner will stay in the AUX mode until the switch is held for 5 seconds. When it is held for 5 seconds, the scanner will start scanning the drive selections again.

Switch 5 Auditory Feedback – the scanner will beep for every scanned position. When a patient cannot see the display, they will hear the beeps and know when the scan moves from one position to the next.

Switch 6 Bluetooth Paring – when in the up position the ASL 102 will look for an ASL accessory to pare to. This is designed to work with the ASL 545 TECLA E and the ASL 557-3 BT switch receiver.

TIMING DIAL

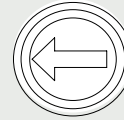

The **Timing Dial** controls the scanning rate. It will change the speed of the scan. The **slowest rate** is indicated by the arrow pointing to the left. The **fastest rate** is reached when the arrow is pointing right. The time each light is on ranges between 0.2 seconds to 4.0 seconds.

ATTENDANT CONTROL

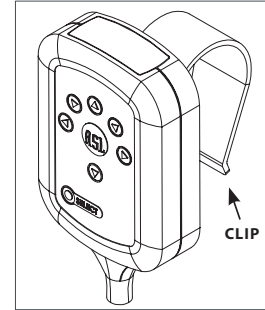

The Attendant Control comes standard with the ASL 102 Single Switch Scanner. It works in conjunction with the Drive Control which will allow the Attendant to help the patient when they need it without completely taking over or changing to another drive. The Attendant is designed to take over driving when loading in a van or in an unmanageable environment. The user can select BT or AUX modes and the patient will be able to use their phone or communication device while the attendant control drives the chair.

The Attendant Control has a clip on the back that can be attached to a push handle for easy access. The flexible cord will allow the Attendant to stand beside the chair and move around freely.

The buttons on the Attendant Control mimic the Drive Control. When the Select button is activated on the Attendant Control while a patient is driving the chair, it will stop moving, but only if the wheelchair electronics are configured for that function. Check with your ATP to be sure. If activated from a stopped position, the chair will move into the next function of the wheelchair, like seating.

DISPLAY

The Display scans in a frequency of use pattern. The blue light is the indication of the direction of function that will be activated if the switch is activated.

For instance, if the switch is activated when the blue light is on in the up arrow, the chair will move forward as long as the switch is activated. If it is in the left arrow, it will go left. When you release the switch, it will go directly back to forward. This will occur after any switch activation, except BT and AUX, which require a sustained switch hold to go back to driving.

There is a brightness sensor on the display when the system is in darker areas. At night, the blue lights will dim. In a light environment, it will be brighter.

